

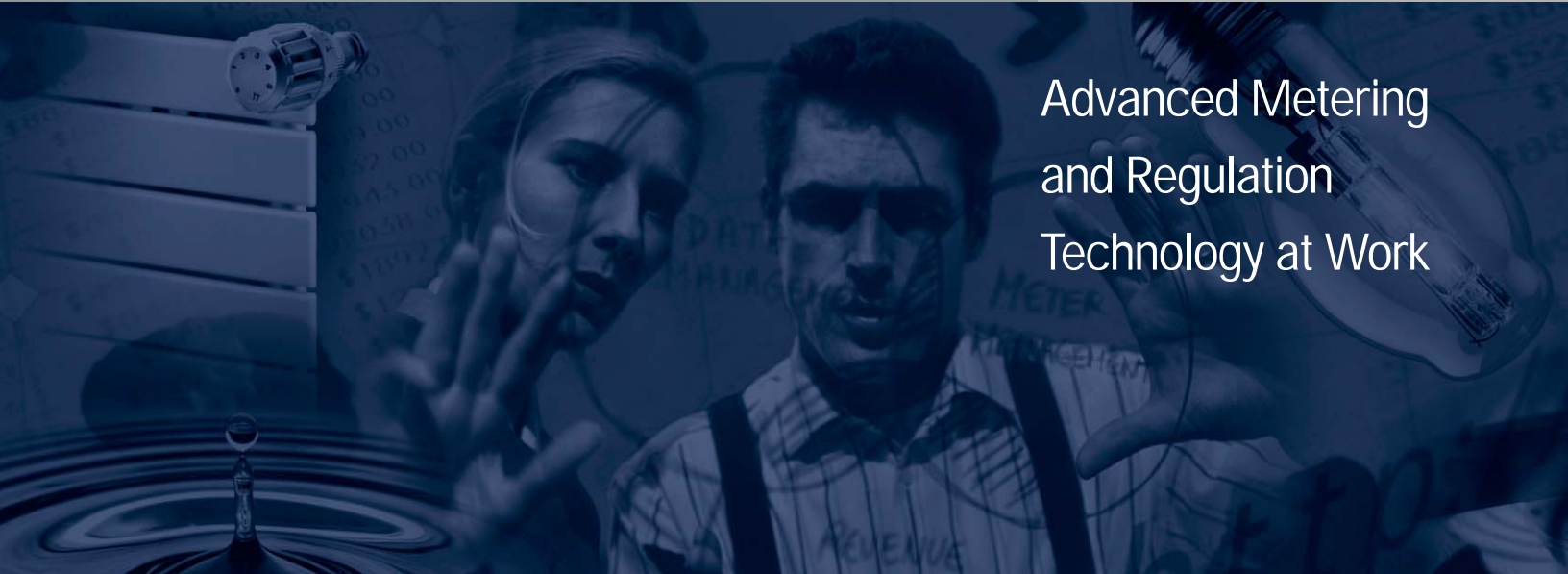

Dattus™ fM2 Commercial & Industrial Gas Meter



Advanced Metering
and Regulation
Technology at Work



Committed to Delivering the Best Possible Results

At Actaris Metering Systems, we are driven to help our customers succeed. As a global leader in measurement systems, we offer over 100 years of experience in the resource measurement business. We use that experience to bring the right combination of people, resources, and technology to deliver results that track to your bottom line.

Our drive to succeed has spawned innovations like the Dattus™ fM2 Gas Meter, the latest generation of electronic gas meters. With no moving parts, this meter offers numerous advantages over existing technologies. The Dattus fM2 can replace current rotary and diaphragm meters (3,000 - 9,000 cfh capacity rated) in many situations, thereby reducing the number of different size meters needed in inventory. In addition Dattus is available with the Gas Micro electronic volume corrector mounted directly in place of the index.

From gas, to electricity, water, and heat, Actaris is the name of quality that millions of customers rely on every day.

Features

- Compact Design
- No Moving Parts
- Integrated Functionality (Pressure, Temperature, Compressibility Correction and Data Logging)
- Fixed Factor Correction
- Volume and Alarm Pulse Outputs
- Configurable Index Orientation
- Instant Flow Rate Display
- Nominal 7-10 Years Battery Life
- Pressure Up to 150 psi
- Capacity Up to 9,000 cfh (base rating)
- Large Rangeability, 400:1

Dattus™ fM2 Gas Meter

Operating Principle

The operation of the Dattus meter is based on the fluidic oscillation principle. The measurement unit is comprised of three functional elements:

- Flow conditioner
- Jet nozzle formation
- Fluidic oscillator chamber

Gas enters (1) the meter and divides into two separate flow paths (2). These two flows recombine (3) as they exit the flow conditioner and enter the fluidic oscillation chamber through the nozzle. This process of dividing the flows eliminates upstream disturbances and creates a well-conditioned flow.

In the fluidic oscillation chamber, a jet is formed (4) as the gas enters through the nozzle. The jet then starts oscillating back and forth (5).

Thermal sensors, located just after the nozzle, detect a temperature variance as the gas jet passes from one side to the other. The volume of gas passed through the meter is obtained by counting the number of oscillations detected by the sensors.

Meter Configuration

Dattus gas meters are available as:

- Basic—the standard meter features and fixed factor capabilities
- Temperature Correction—the basic version with temperature probe mounted in the gas flow.

Standard Features

The basic meter performs volume metering based on the gas pressure and temperature in the meter. The functions available are shown below:

- Gas volume totaling
- Fixed factor correction
- Non-volatile memory for storing values and data
- Optical communication port for reading/writing of values
- Eight item programmable display
- Magnetic switch to change display values

Optional Features:

In addition to the standard functionality of the basic configuration, the following options can be added:

- Temperature correction using a temperature probe mounted in the gas flow
- Volume and alarm pulse outputs
- Push button to change display values
- Gas Micro electronic volume corrector (EVC)

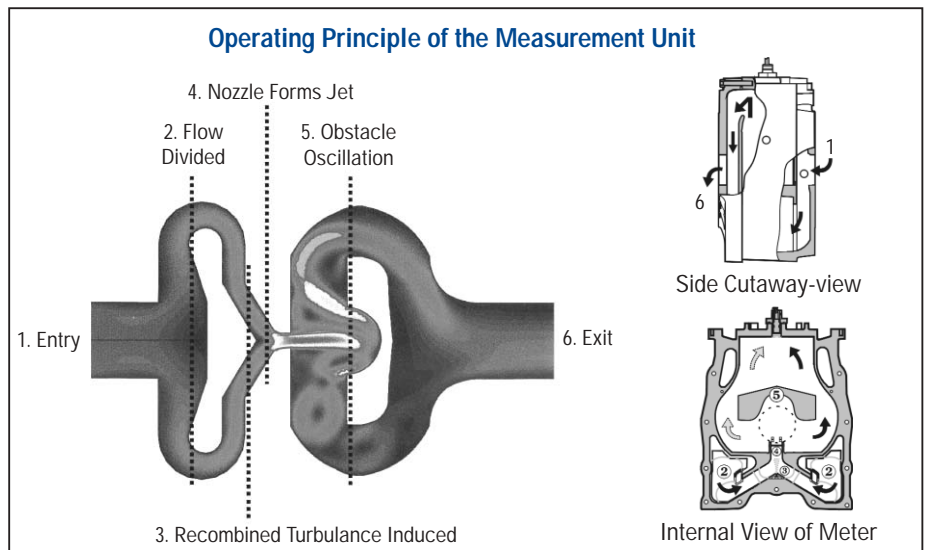

Specifications

| | |
|--|---|
| Meter Type: | Dattus |
| Meter Model: | fM2 |
| Comparable Meters: | 3,000 acfh to 9,000 acfh |
| Flanges: | 2" and 3" ANSI 125 |
| Flange to Flange Length: | 6.75" |
| Maximum Allowable Operating Pressure (MAOP): | 150 psig |
| Temperature Range: | -40°F to 140°F |
| Display: | Configurable up to 8 digits to show meter quantities and alarms |

Rangeability

| | |
|--------------------|------------|
| Dynamic Range: | 400:1 |
| Minimum Flow Rate: | 22 acfh |
| Maximum Flow Rate: | 9,000 acfh |

Pulse Output

| | |
|-----------------|-------------------------------|
| Pulse type: | Low frequency, standard Namur |
| Form type: | A |
| Pulse duration: | 250 ms |
| Pulse Value: | User Scalable |

Temperature Probe

| | |
|-------------------|--|
| Type: | PT1000, platinum resistance thermistor (RTD) |
| Typical accuracy: | 0.1% of absolute measurement |

Construction

| | |
|-------------------|--------------------------------------|
| Measurement Unit: | Cast aluminum A356T6 |
| External Cover: | ASA (Acrylonitrile Styrene Acrylate) |
| Index Housing: | UV stabilized polycarbonate |

Weight

37 Lbs.

Dattus fM2 Dimensions (Inches)

| A | B | C | D | Thread Depth |
|-------|-------|-------|-------|--------------|
| 16.5" | 10.6" | 6.75" | 10.0" | 1.00" |

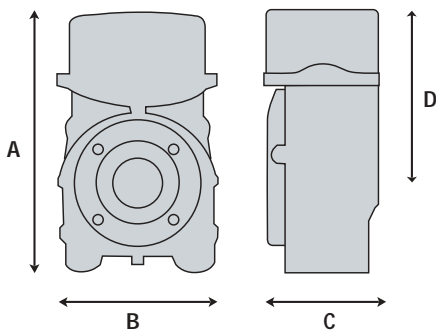

| Flange Type | Bolt Pattern Diameter* |
|-------------|------------------------|
| ANSI 125 2" | 4.75" |
| ANSI 125 3" | 6.00" |

Note: Flanges receive four 1-3/4" x 5/8"-11 UNC 2B Bolts

Dattus Accuracy and Rotary Meter Comparison

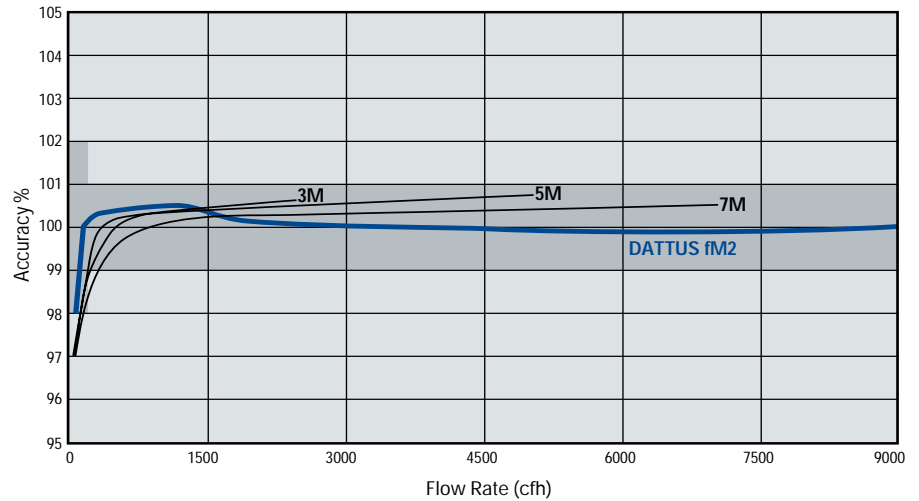

Pressure Drop, Gas (0.6 Specific Gravity) @ Atmospheric Conditions

| Dattus Model | Flange Version | Flow Rate (acfh) | Pressure Drop gas (in w.c.) | Dynamic Range, +/- 2% | Dynamic Range, +/- 1% |
|--------------|----------------|------------------|-----------------------------|-----------------------|-----------------------|
| fM2 | 2" | 9000 | 6.38 | 409:1 | 150:1 |
| | | 7968 | 5.00 | 362:1 | 133:1 |
| | | 7000 | 3.89 | 318:1 | 116:1 |
| | | 5000 | 2.06 | 227:1 | 83:1 |
| | | 4918 | 2.00 | 225:1 | 82:1 |
| | | 3481 | 1.00 | 158:1 | 58:1 |
| | | 3000 | 0.75 | 136:1 | 50:1 |
| | 2457 | 0.50 | 112:1 | 41:1 | |
| | 2750 | 0.50 | 125:1 | 46:1 | |
| | 3" | 9000 | 5.06 | 409:1 | 150:1 |
| | | 8905 | 5.00 | 405:1 | 148:1 |
| | | 7000 | 3.14 | 318:1 | 116:1 |
| | | 5535 | 2.00 | 252:1 | 92:1 |
| | | 5000 | 1.64 | 227:1 | 83:1 |
| 3871 | | 1.00 | 176:1 | 65:1 | |
| 3000 | | 0.61 | 136:1 | 50:1 | |

Pressure Drop (2" and 3" Version)

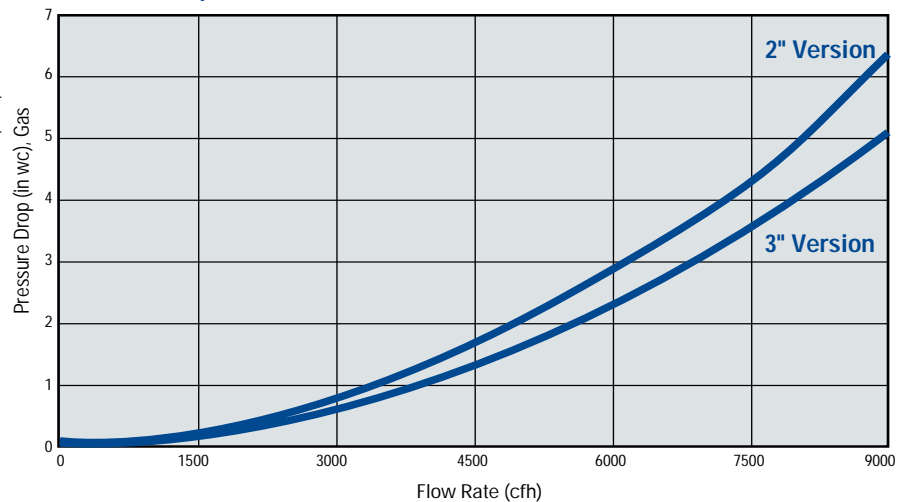

Dattus Capacities at Indicated Metering Pressures

| Metering Pressure PSIG | 1 | 5 | 25 | 60 | 100 | 150 | 175 |
|------------------------|-----|------|------|------|------|-------|-------|
| MSCFH | 9.6 | 12.0 | 24.3 | 45.7 | 70.1 | 100.6 | 115.9 |

Warranty

Actaris Metering Systems, 970 Highway 127 North, Owenton, Kentucky 40359-9802, warrants this gas product against defects in materials and workmanship for the earlier of one (1) year from the date the product is shipped by Actaris or a period of one year from the date the product is installed by Actaris at the original purchaser's site. During such one-year period, provided that the original purchaser continues to own the product, Actaris will, at its sole option, repair any defects, replace the product or repay the purchase price.

This warranty will be void if the purchaser fails to observe the procedures for installation, operation or service of the product as set forth in the Operating Manual and Specifications for the product or if the defect is caused by tampering, physical abuse or misuse of the product.

Actaris specifically disclaims all implied warranties including those of merchantability or of fitness for a particular purpose. Under no circumstances will Actaris be liable for incidental or consequential damages of any kind whatsoever.

Actaris' liability for any claim of any kind, including negligence and breach of warranty for the sale and use of any product covered by or furnished, shall in no case exceed the price allocable to the product or part thereof which gives rise to the claim.

In the event of a malfunction of the product, consult your Actaris Service Representative or Actaris Metering Systems, 970 Highway 127 North, Owenton, Kentucky 40359-9802. (800) 490-0657

Reference Information

- Dattus™ Technical Reference Guide document no. GA-0007-GB-04.01, part no. DO202201

Actaris Metering Systems
970 Highway 127 North
Owenton, Kentucky 40359-9302, USA
Tel: 800 490 0657
502 484 5747
Fax: 502 484 6223

www.ActarisUSgas.com

GA - 0013 - GB - 10.02
© Copyright 2002, Actaris U.S. Gas, Inc.

Distributed by:

