



ACE3000 type 100/110

Residential Three-Phase Electronic Meter

- ▶ Active energy measurement
- ▶ Single and double tariff drum register
- ▶ Import and export measurement
- ▶ Compatible with current connection standard
- ▶ Anti-tampering registration mode
- ▶ Long-term performance



▶ ACE3000 type 100

The ACE3000 type 100/110 series is part of Actaris' latest generation of electronic polyphase meters specifically designed for residential applications and the continuation of a long and successful story in metering.

An outstanding feature of this robust meter is its easy-to-read drum register that keeps the user continuously up-to-date with consumption.

Cost Effective Revenue Metering

Designed to provide cost-effective functionality the ACE3000 type 100/110 series combines proven metering technology with a reliable electromechanical register. Available in different registering modes, it can be used for all single and double tariff residential applications as three-phase, bi-phase or single-phase meter, depending on the network. The meter's pulse outputs allow system integration whenever required.

Reliability

Digital measurement technology with proven long-term capability, use of longlife components and special care in the manufacturing process guarantee consistent accuracy and reliability over the meter's life time. Robust and extensive protection features minimise the risk of interference and protect the meter from dust and water penetration in accordance with IP53.

Handling and Installation

The meter's ergonomic design and innovative installation guides makes the installation and set-up simple and minimises stock and transportation cost. Adapted to current connection standards the ACE3000 type 100/110 meters are available in two sizes to be compatible with existing installations and test benches.



Basic Residential

- ▶ Active energy measurement
- ▶ Simple consumption monitoring
- ▶ Diverse anti-fraud features



High Residential

- ▶ Optional double tariff system
- ▶ Wide current range
- ▶ Data interface for basic load management
- ▶ Active export energy (e.g. green energy suppliers)

▶ Markets of the ACE3000 type 100/110



▶ Firmware development of ACE3000 type 100/110

Adding Value

Added value

Through the innovative design and use of state-of-the-art metering technology the ACE3000 type 100/110 meters offer benefits to both utilities and end-users, adding significant value to all steps of the metering process.

Utility Benefits

▶ Reduced logistical cost

Thanks to the effective design and low weight of the meter, stock can be reduced to a minimum and transport costs can be kept low. The same meter can be used for single and polyphase applications.

▶ Reduced cost of certification

The certification can be done very efficiently as the calibration links can be opened and closed without the use of screws.

▶ Easy installation

The increased opening diameter of the mains terminals including the neutral makes the ACE3000 type 100/110 meters easy to install. The auxiliary terminals are easily accessible and allow wire connection even with sleeves. Start-up is supported by indicator LED for phase lost and phase rotation.

▶ Simple meter reading

The traditional drum register offers excellent readability and reliability and is even suitable for self-reading purposes. As an additional advantage, the register can be read when the meter is de-energised.

▶ Revenue protection

Anti-fraud features, e.g. the cover extended to the ground plane, protection of the calibration links and the always positive registering mode guard against tampering.

▶ Resistance to environmental hazards

The ACE3000 type 100/110 series has been tested to cope with severe environmental conditions, even exceeding the requirements of relevant standards, such as electromagnetic disturbances, impulse voltages and variations in network conditions (loss of power, under- & over-voltage).

End-User Benefits

▶ Visibility of consumption

The easy-to-read drum register informs the end-user about current energy consumption even when the premises are de-energised.

▶ Registering of export energy

Energy generated and supplied by the end-user can be permanently displayed on the meter by a second register.

▶ Indication of abnormal conditions

Abnormal operation conditions, such as phase lost, reverse energy flow and reverse phase rotation are indicated by status LEDs.

▶ System integration

Equipped with 1 or 2 SO pulse outputs the ACE3000 type 100/110 meters can be easily integrated into the end-user's load management system.

Characteristic load curve at U_n 50Hz and at 23°C (I_n = nominal current)

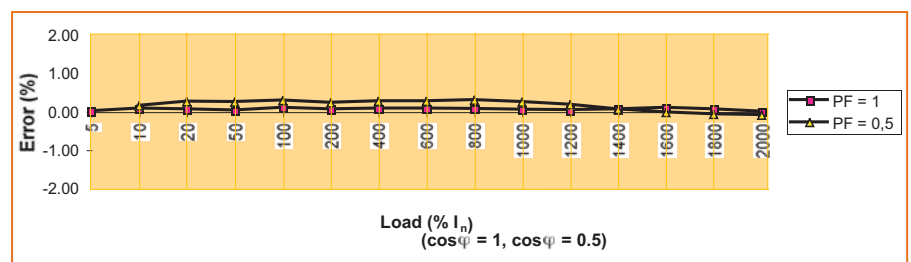

Key Features

▶ Active Energy

Measurement of active energy in both directions, import and export

▶ Current Ranges

- Dynamic range from 15mA to 100A, direct connection
- Maximum load range 5(100)A

▶ Network

Suitable for most common network types:

- 3-phase 4-wire
- 3-phase 3-wire
- 2-phase 3-wire
- 1-phase 2-wire

▶ Tariff Application

- Single tariff > ACE3000 type 100
- Double tariff > ACE3000 type 110
- External floating tariff control, optionally phase or neutral switching

▶ Registering Modes

- Mode 1: import per phase (anti-reverse function set for each phase)
- Mode 2: Ferraris-like (simulation of

induction watt-hour meter)

- Mode 3: unidirectional (always positive register)
- Mode 4: import and export (with two independent registers)

▶ Data output

- Optional up to 2 pulse outputs according to IEC 62053-31 type A (SO output).

▶ Auxiliary Terminals

- Up to 7 auxiliary terminals for tariff control and pulse output
- Up to 3 extra voltage terminals

▶ Anti-tampering feature

- Meter cover overlaps the base until the ground plane
- I/P links can be protected and sealed
- Unidirectional mode: the meter measures the absolute sum of total and export energy
- Indication of reverse energy flow
- Independent seal of the meter body and terminal cover.

Quality

Because of our strong commitment to customers, Actaris regularly conducts environmental and ageing tests beyond the standard meter tests on sample meters from the production line. This enables permanent monitoring of not only the quality of the product but also the quality of the components supplied. The meters' efficient operation is validated in extended field trials under real conditions before they go onto the market.

The ACE3000 type 100/110 meters are manufactured to the highest standards of quality, reliability and accuracy and have been designed for a long service life, assuring the customer's investment. Refurbishment costs over the life of the product can therefore be kept very low.

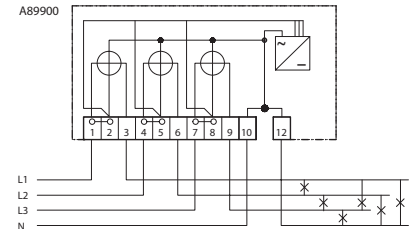

▶ Single tariff (DIN circuit no. 4000)

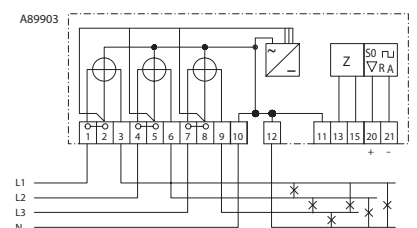

▶ Double tariff with pulse output (DIN circuit no. 4702)

Accessories

Documentation	User Guide
	Installation Guide
	Approval and type test certificates

Dimensions

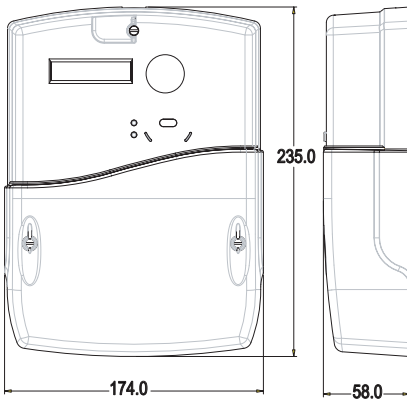

► Main dimensions - ACE3000 type 100

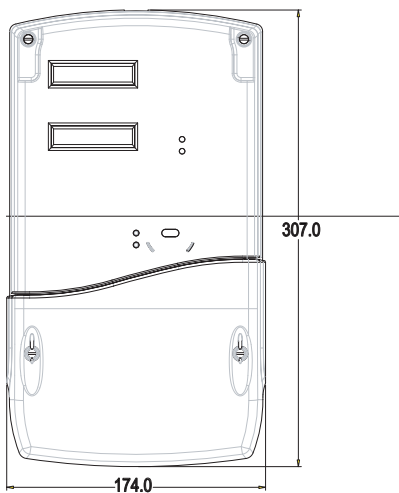

► Main dimensions - ACE3000 type 110

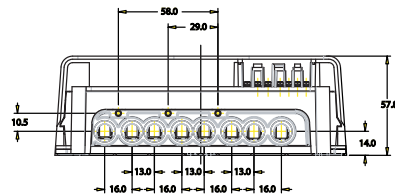

► Terminal arrangement

Technical Specifications

Parameter	Characteristics
Meter Type	Static polyphase watt-hour meter
Standard	IEC 62053-21:2003 for indoor application (former IEC 61036)
Network	3-phase 4-wire or 3-phase 3-wire network
Measuring scope	Active energy in two directions (P+, P-)
Class index	Class 2 (optional class 1)
Reference frequency	50Hz or 60Hz
Reference voltage	3 x 230/400V, others on request
Operating voltage range	-20% to + 15% Un
Power consumption (per phase)	Voltage circuit < 0.4 W resp. < 3.0 VA @ 230V Current circuit < 0.1VA @ 5A
Basic current	5A, 10A or 20A
Maximum current	60A, 80A or 100A
Starting current	0,3% Ib (min 15mA)
Meter constant	programmable 500 or 1000 imp/kWh
Operating temperature range	-25°C to + 60°C (-40°C to + 60°C on request)
Limit temperature range of operation	-40°C to + 60°C @ 3 x 100A
Temperature range for storage and transportation	-40°C to + 70°C
Register	Drum register with 7 digits, size 5.2 x 2.6mm
Number of decimals	One or no decimal
Number of tariffs	Single or double tariff for external control
Control voltage	230V
Indicators	Multi-function LEDs for reverse energy, phase failures, phase sequence and critical errors
Pulse output	Up to 2, according to IEC 62053-31 Type A (SO output) programmable for serial data output
Pulse constant	Programmable 250 or 500 imp/kWh
Terminal arrangement	According to DIN 43857 part 2
Material of mains terminals	Brass, optional steel, zinc plated
Diameter of current terminals	8.0mm
Diameter of neutral terminals	8.0mm
Auxiliary terminals	up to 7, diameter 3.2mm
Voltage terminals	up to 3, diameter 3.2mm
Protection class	IP53 according to IEC 60529
Immunity to impulse voltages	> 8kV (1,2/50µs)
Immunity to HF fields	> 15V/m (up to 2GHz)
Meter size (W x H x D)	ACE3000 type 100: 174 x 235 x 58mm (with terminal cover) ACE3000 type 110: 174 x 307 x 58mm (with terminal cover)
Meter weight	ACE3000 type 100: 1.0 kg ACE3000 type 110: 1.3 kg